



Compressor
Voltage Code : FZ

CAJ4492Y-FZ

High Temp. Commercial (HP)

220 - 240V 1~ 50 Hz

R134a

AJ4492Y-FZ1B

Conditions	Frequency	Nominal Cooling Capacity		Sound Power ISO3745 / ISO 3743-1
		Watts	BTU/h	
EN12900 / R134a	50 Hz	2108	7187	58 dBA

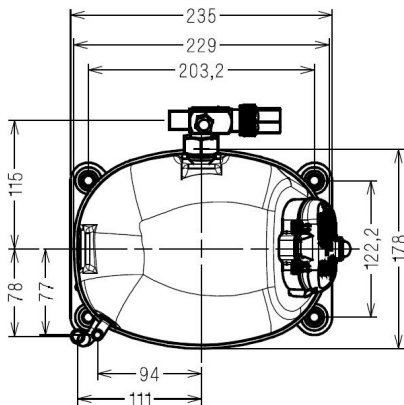
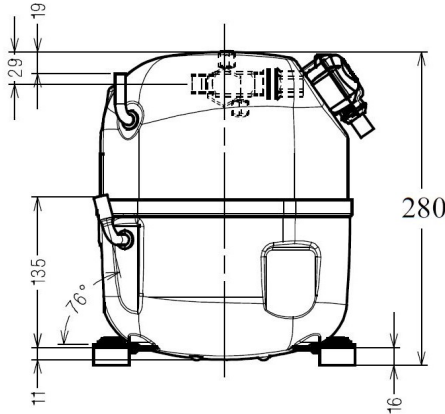

* EN12900 : T°Cond. 50.0°C / T°Evap. 5.0°C / T°Return gas temp.. 20.0°C
T°Subcooling. 0.0K

Certificates :



Displacement (cc)	25.95
Net Weight (Kg)	20.3
Oil Quantity (cc)	475.0
Oil Type	Polyolester
Expansion Device	Capillary_Tube/Expansion_Valve
Cooling	Fan
Main Winding (Ohm)	2.9
Start Winding (Ohm)	12.8
Current	
RLA (A)	5.7
MCC (A)	8.9
LRA (A)	28
Electrical Equipment	CSIR
Overload	MST18AIN
Time Check	7.5s - 14s / 20.7 A
Open Temp	120° C
Close Temp	69° C
Optional	T0750
Start Capacitor	64 µF / 330 V
Potential Relay	RVA4G**
Pick Up	180/195V
Drop Out	40/105V
Refrigerating connection for OD	
Suction Tube	12.7 (1/2")
Discharge Tube	7.9 (5/16")
Process Tube	6.35 (1/4")

Note : Tecumseh reserves the right to change information contained in this document without notification.



Tecumseh

CAJ4492Y-FZ	Tension FZ : 220 - 240V 1~ 50 Hz
--------------------	---

Les performances sont données dans les conditions EN12900 :	Gaz aspirés :	20.0 °C
Condition Dew	Sous refroidissement :	0.0 K
The performance data are in EN12900 conditions :	Return gas :	20.0 °C
Dew Condition	Subcooling :	0.0 K

50 Hz R134a											
											
										N°214LS-FZ	
4 T condensation	5 T évaporation	(°C)	-25	-20	-15	-10	-5	0	5	10	15
30	1 P frigorifique	(Watt)	592	828	1113	1455	1864	2348	2915	3574	4334
	2 P absorbée	(W)	415	479	536	588	636	680	723	764	804
	3 I absorbée	(A)	4.32	4.39	4.47	4.58	4.70	4.85	5.01	5.20	5.40
40	1 P frigorifique	(Watt)		664	925	1230	1590	2013	2507	3081	3744
	2 P absorbée	(W)		483	562	634	701	763	823	880	935
	3 I absorbée	(A)		4.37	4.53	4.71	4.91	5.13	5.37	5.62	5.90
50	1 P frigorifique	(Watt)			722	996	1313	1681	2108	2603	3174
	2 P absorbée	(W)			560	657	748	834	915	993	1068
	3 I absorbée	(A)			4.55	4.81	5.08	5.37	5.69	6.02	6.37
60	1 P frigorifique	(Watt)				748	1028	1346	1711	2133	2619
	2 P absorbée	(W)				652	772	886	994	1098	1198
	3 I absorbée	(A)				4.87	5.22	5.59	5.97	6.38	6.81

© 2019 Tecumseh Products Company
All rights reserved

1 = cooling capacity 2 = power input 3 = current 4 = condensing temperature 5 = evaporating temperature

Nota : Tecumseh se réserve le droit de modifier les informations contenues dans ce document sans préavis.
Note : Tecumseh reserves the right to change information contained in this document without notification.